

IMM Quality Boat Lifts

The Smart Choice.



Product Catalog



www.iqboatlifts.com



Table of Contents

Why Choose Imm Quality?.....4
Custom Design Experts.....6
IMM Quality Drive Systems.....7
Vertical Lifts.....8
Superlift.....10
Titan Yacht Lifts.....12
Elevator Lifts.....14
PWC Lifts.....16
Boathouse Lifts.....18
Kayak Lifts.....20
Beamless Lifts.....22
Trident Lifts.....23
Deck Lifts.....24
Floating Docks and Gangways.....25
Ascension Stair Lift.....26
Options and Accessories.....28





Why Choose IMM Quality?

At first glance, different brands of lifts may look similar, but upon closer inspection, you will find that IMM Quality Boat Lifts are built better than all the rest. IMM Quality Boat Lifts has been family owned and operated since inception, with over three generations of fabricating experience and engineering knowledge. Our longevity in business and unmatched warranty are testament to our claim that we manufacturer the world's best boat lifts. We can stand behind our products because we employ only the best engineers, designers, machinists, assemblers and ASW D1.2 aluminum certified welders to ensure that our pride and dedication shows in every product that leaves our factory. Read further to see how IMM Quality Boat Lifts are built like no other lift for years of trouble-free use.

Our Commitment

IMM Boat Lifts and **Quality Boat Lifts** were two of the country's premier boat lift manufacturers. In 2008, the two companies merged to create the world's largest and leading boat lift manufacturer. IMM Quality Boat Lifts manufactures our full line of products at our state-of-the-art facilities in Fort Myers, Florida. IMM Quality Boat Lifts is committed to manufacturing lifts that are safe, long-lasting, dependable, easy to use and aesthetically pleasing. We are dedicated to developing products that will exceed our customer's expectations while adhering to world class engineering standards. In keeping with this commitment, we use only the very best materials and manufacturing techniques available in the industry. You cannot get higher quality or a better value anywhere else in the boat lift industry. Dependability was key when we built our first lift way back in 1982, and it still is today. We believe that your time on the water should be spent relaxing with family and friends, not fixing broken equipment. Rest assured, that with an IMM Quality boat lift you can relax and enjoy your time on the water doing what you love.

Construction

IMM Quality Boat Lifts has a highly advanced, state-of-the-art 30,000+ square foot manufacturing facility. Our investment in the best machinery like CNC plasma cutters, CNC auto-feed band saws, CNC lathes, CNC punches, CNC mills and CNC routers gives us the most advanced manufacturing facility in the industry. Not only does this equipment give us the ability to design stronger, more reliable lifts and produce designs other companies cannot make, but this equipment greatly improves the manufacturing process, providing greater consistency and tighter tolerances than can be achieved elsewhere. This also allows us to make all of the parts for our lifts



Factory Overhead



CNC Lathe

in house using fully computerized machines, which guarantees the consistent high quality we demand. Our advanced manufacturing equipment allows us to modify existing parts and build novel parts easily, and this unique capability coupled with our engineering expertise is why we are the leading custom boat lift manufacturer. Finally, our commitment to state-of-the-art manufacturing processes and product safety testing has given us great pride in our products and drives us to ensure that every product that leaves our factory exceeds our customer's expectations.

All of these factors have resulted in dozens of patents (more patents than every other boat lift manufacturer combined) and many more innovative design features. Take a look at any design feature on any boat lift. Chances are IMM Quality Boat lifts patented it or designed the feature and brought it to market. Boat lift innovations from IMM Quality include:

- Custom aluminum extrusions:
 - Our top beams are made with stepped channel which provides structural support for the drive bearing blocks and eliminates shear loads on the weld, a major improvement over standard C channel used by our competitors. (Figure A.)
 - The shape of our aluminum bunk extrusion was designed so that the non-marring UV resistant white vinyl slides into integrated grooves and requires no top-side rivets. Our bunk brackets allow the angle of the bunks to be adjusted easily to fit your hull like a glove. Our competitors use black plastic prone to marring that is attached by top-side rivets that can scratch your hull. The angle of their bunks is fixed by the shape of their extrusion which causes side-loads on the structure and can result in catastrophic collapse of their bunks. (Figure B.)
- All of our lifts are designed with cable keepers or cable rollers to ensure proper cable winding and extend cable life.
- The carriage arms on our elevator lifts use heavy duty 1" thick gusset plates in this critical joint. These gussets have CNC machined grooves into which the flanges of the carriage I-beams fit perfectly. Therefore, the gussets provide structural support and ensure the correct geometry for the carriage arms. We weld this joint and use reinforcing bolts to construct the strongest carriages in the industry. (Figure C.)
- Our maintenance-free bearings, bushings and sheaves require no lubrication, providing industry best durability and reducing service costs. Our competitors use bearings and sheaves that use grease and require frequent, costly maintenance. The unsightly black grease also leaks out of these bearings and sheaves, getting on your lift, dock and boat. What a hassle and mess! (Figure D.)

Figure A.

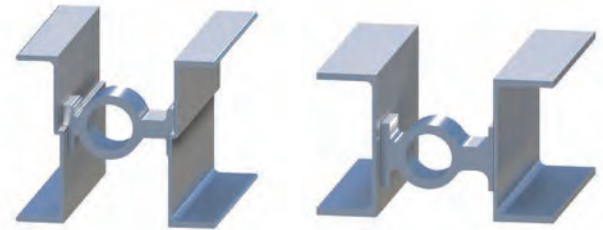

Stepped Channel

Standard C-Channel

Figure B.

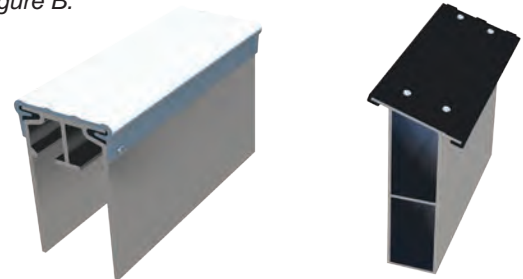

IMM Quality Bunks

Competitor Bunks

Figure C.

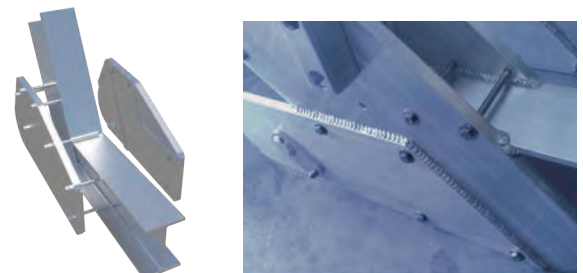

Our CNC machined gusset plates are the strongest in the industry.

Figure D.

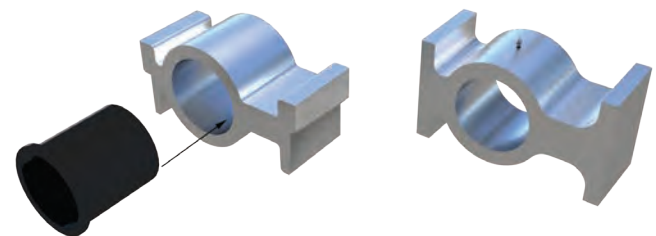

IMM Quality No-Lube Bushing

Messy Greasable Bearing

- Drive tubes are treated with Gatorshield electroplating to prevent corrosion.
- Our patented wedge lock allows for easy adjustment of cable length to level the cradle or adjust the pitch of the boat. Wedge locks also make cable replacement a snap. Our competitors have fixed cable ends that can't be adjusted once installed and must be cut off and repaired during cable replacement. (Figure E.)

While all the other boat lift manufacturers try to play catch up, IMM Quality continues to lead the field.

Service and Warranty

Our goal is to provide the best customer service experience possible. Our sales team, custom design services, technical support, parts service and dealers work diligently to make this goal a reality. Through extensive feedback both from and about our dealers, we are constantly striving to improve our customer service. We believe the thousands of satisfied customers and extensive testimonials clearly show the quality of our customer service.

We provide the most comprehensive warranty in the industry. A few other companies have put out warranties that try to match ours, but read them carefully. They are limited warranties. Ask around with other homeowners about their experience with these companies. Then take a look at our warranty. A 15 year warranty on our structures, our **cycloidal drives are warranted for the life of the lift**, a 5 year warranty on all other drives, and a 2 year warranty on all other components. Furthermore, all our lifts and the boat you put on it are protected by the most comprehensive products liability insurance available on the market.

Dependable, patented, unsurpassed design, excellent service and most of all, built like no other lift for years of trouble-free use.

Custom Design Experts

Our IMM Quality (IQ) engineers designed our lifts to be industrial grade, heavy duty machines that last a lifetime. Our designs are developed in house by our full-time engineering team using the latest 3D modeling and structural analysis software. Our IQ engineers have developed our patented and custom designs to exceed the toughest building codes and to far exceed the performance of any other boatlift on the market. Our lifts were also designed smarter so that they are easier to use and require less maintenance than other lifts. Heavier materials, all aluminum structural components, stainless steel

Figure E.



Patented Wedge Lock

Non-Adjustable

cables and hardware, welded construction, totally enclosed drives and motors, tribopolymer maintenance free bearings, wedge locks, etc. It is attention to detail that really sets our lifts apart and we engineer our lifts with all the details in mind so you don't have to worry about them!

Our IQ designs provide the lowest cost of ownership among any lift on the market along with unsurpassed durability to give you peace of mind over costly and time consuming repairs. How do you really know that we are serious about product quality? Our dedicated in-house test facility is larger (12,000+ sq ft.) than the entire factory of most boat lift companies. All our IQ designs have been thoroughly tested to make sure that what makes sense on paper also exceeds our rigorous performance standards in the real world. With continuous improvement based on our extensive experience and customer's needs, we have perfected the art of building the best lifts in the industry!

Another thing that sets us apart is our tremendous experience. With over three generations of engineering and fabrication experience we know how to build the best boat lifts on the market. What may seem difficult and new to other companies, we have seen many times before. This means that IMM Quality does not build one-size-fits-all products, we build lifts to accommodate your individual needs. From catamarans, to deep keel sailboats, to sea planes, to large capacity yachts, to platform lifts with integrated decking, we are always available to help you in your design, location, and installation requirements for the perfect lift for your dream boat. We design and manufacture complete custom cradle systems to fit the boat manufacturer's recommended bunk placement. Our full custom boat lift services make sure that you get a lift system that is perfectly sized, equipped and priced for your needs.

IMM Quality Drive Systems

Chain Drive

The IMM Quality chain drive transmission is a major improvement over the obsolete flat plate drive. When the army chose a transmission for their tracked vehicles, did they use a belt transmission prone to slippage and breakage? Do Caterpillar, John Deere and other manufacturers of heavy-duty earth moving equipment use belt drives? No way! They use chain drives. When lives are on the line and the job is too important for break downs, the chain drive is the only choice for gear-driven transmission. Given the extreme conditions of the saltwater environment, the chain drive's shock-load ruggedness, efficiency, safety, and battle-tested dependability make the chain drive simply the best and most economical choice in this extreme application.

- Specifically designed for boat lift applications.
- Compact, low-profile design with fully enclosed power head to protect the drive system from the harsh saltwater environment.
- Legendary safety and durability at an economical price.
- Routine maintenance made easier by an integrated lubrication / inspection port.
- 5 year manufacturer's warranty on the mechanical components, 2 year warranty on electrical components.
- Standard on our Alumavator lifts.
- Available in a high speed version that is twice as fast.

The Platinum Drive

Why settle for gold when you can own the Platinum drive? A superbly engineered aluminum double worm transmission for a maintenance-free direct drive-to-shaft connection. The Platinum drive was designed to meet the environmental challenges associated with marine boat lifts, to increase the speed of lift operation and to provide maintenance-free ownership – a convenience that better suits modern on-the-go lifestyles.

- Compact, low-profile design with fully enclosed power head to protect the drive system from the harsh saltwater environment. No exposed mechanical parts.
- Completely maintenance-free, sealed aluminum gear box.
- Smooth, clean, fast, reliable, low noise level and the convenience of no routine maintenance.
- 5 year manufacturer's warranty on the mechanical components, 2 year warranty on electrical components.
- Standard on our Platinum lifts.

Cycloidal Drive

Our Cycloidal drive incorporates a gearless high-efficiency cycloidal reducer that generates up to 34,700 inch pounds of output torque at an efficiency of greater than 90%. What does this amazing torque and efficiency mean? Without any gears to grind together, wear out and lose teeth, our gearless cycloidal drives are the most powerful on the market, they are the most durable drive system available and nothing is faster at lifting your boat. More than twice as fast as the nearest competitor's high speed drive system. When only the absolute best will do, the IMM Quality Cycloidal drive is the only choice.

- Rugged cast aluminum cover fully encloses the drive component protecting them from the harsh marine environment.
- Continuous duty, high service factor motor with failsafe brake that prevents backdriving even when the power is out.
- Smooth, safe, unparalleled lifetime durability and the fastest drive available.
- **Lifetime manufacturer's warranty on the cycloidal reducer***, 2 year warranty on the electrical components.
- Standard on our Superlift and Titan yacht lifts.

(*see warranty for full details)



Alumavator powerhead



Platinum powerhead



Superlift powerhead

Vertical Lifts

Alumavator & Platinum



FOUR PILE LIFT

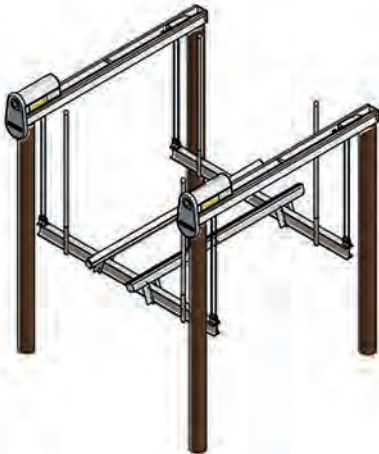

- Available Capacities (lbs.):
- 4,500
 - 7,000
 - 10,000
 - 13,000
 - 16,000
 - 20,000
 - 27,000

EIGHT PILE LIFT

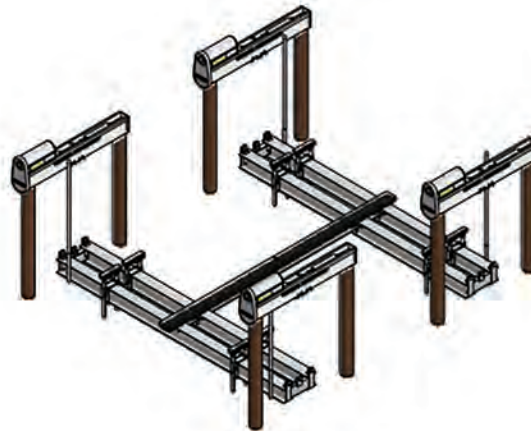

- Available Capacities (lbs.):
- 32,000
 - 40,000
 - 54,000.

These four and eight pile lifts are traditional top beam designs. All are built to withstand the harsh saltwater environment using 6061-T6 marine grade aluminum and stainless steel hardware. All IMM Quality boat lifts are welded for superior structural integrity with bolts only used on components that require adjustment. All of our vertical lifts feature grooved aluminum winders, stainless steel aircraft cables, custom extruded top beam stepped channel for superior structural support of the drive shaft, maintenance-free pulleys and drive bearings that require no lubrication, patented wedge locks for easy cradle

adjustment and integrated cable keeping systems. The vertical lifts are available in two styles: **1. The Alumavator**, featuring our chain drive, a premium lift at an economical price. The Alumavator comes standard with carpeted wooden bunks, Bonita manual control and GFCI. **2. The Platinum**, featuring a double worm direct drive, was engineered for a truly maintenance-free experience. The Platinum comes standard with white vinyl covered aluminum bunks that are guaranteed not to float and a remote control box with handheld transmitter.



Standard Features:

Alumavator

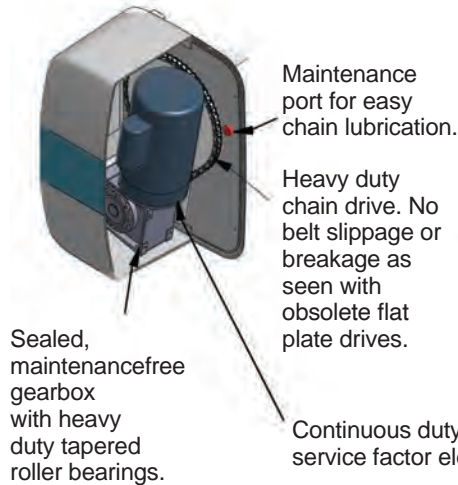

Platinum

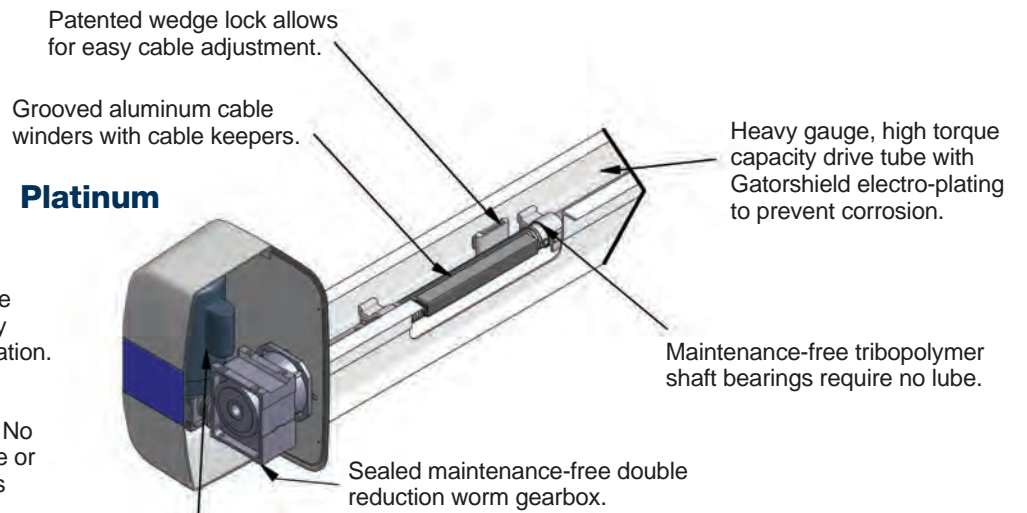

Heavy duty rotomolded covers protect mechanical and electrical components from the elements.

Heavy duty reinforced guide post base with pvc covered guide posts that are easily adjustable.

Standard on **Platinum**, custom extruded aluminum bunks with UV resistant non-marring pvc caps. **Alumavator** comes standard with fully carpeted pressure treated wood bunks.

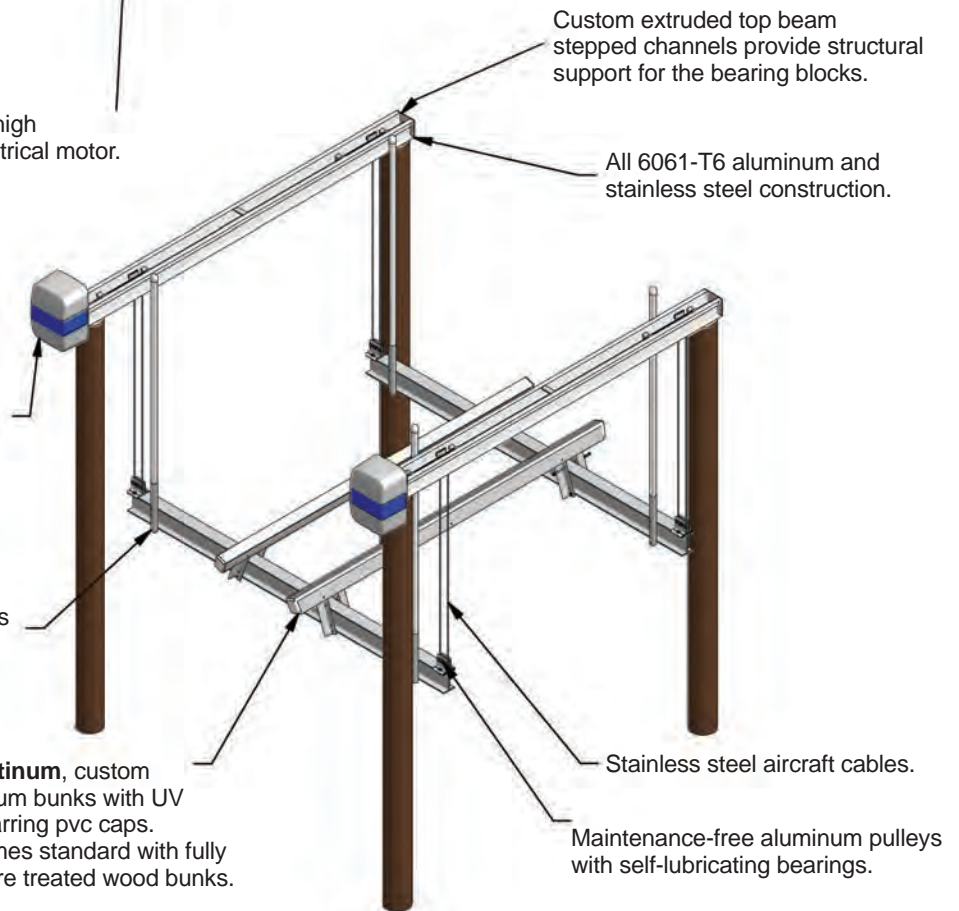

Alumavator Options:

- Available in a High Speed version that is twice as fast
- Remote control with handheld transmitter
- Aluminum bunks

General Options:

- Auto-stop limit switches
- Top beam covers
- Walkboards, stern platforms and steps
- ThruFlow decking
- Solar power

SuperLift



FOUR PILE LIFT

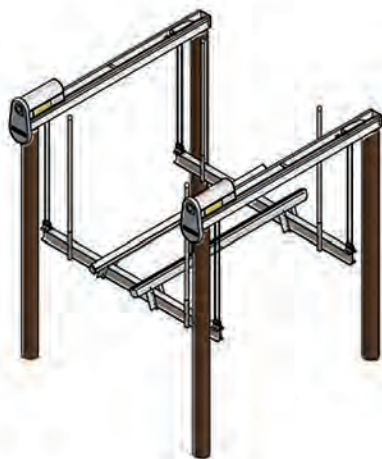

- Available Capacities (lbs.):
- 5,000
 - 7,000
 - 10,000
 - 14,000
 - 18,000
 - 22,000
 - 27,000
 - 33,000

EIGHT PILE LIFT

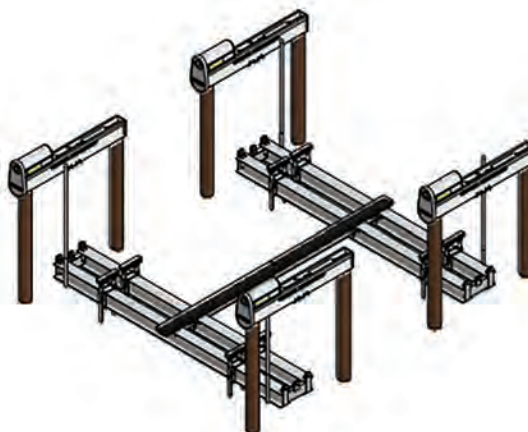

- Available Capacities (lbs.):
- 44,000
 - 54,000
 - 66,000

The IMM Quality Superlift was developed for extended frequent use in marina applications where extreme durability, reliability and long life are essential. Given its' performance, the Superlift has developed a reputation as the finest industrial duty boat lift ever made, and has now gained a following among discriminating homeowners as a reliable lift they can trust. The Superlift incorporates a gearless high-efficiency cycloidal drive that is the most powerful and durable drive system on the

market. Without any gears to grind together, lose teeth, wear out and lock up, our gearless cycloidal drives have unsurpassed durability and legendary reliability. We are so confident in our cycloidal reducers that we are able to warrant them for life*. And nothing is faster at lifting your boat, more than twice as fast as the nearest competitor's high speed lift (see comparison table). The Superlift sets the standard on quality.



Superlift Options:

- Custom designed high speed version is twice as fast
- Top beam covers, walk boards, stern platforms, custom decking designs and steps



(*see warranty for full details)

Standard Features:

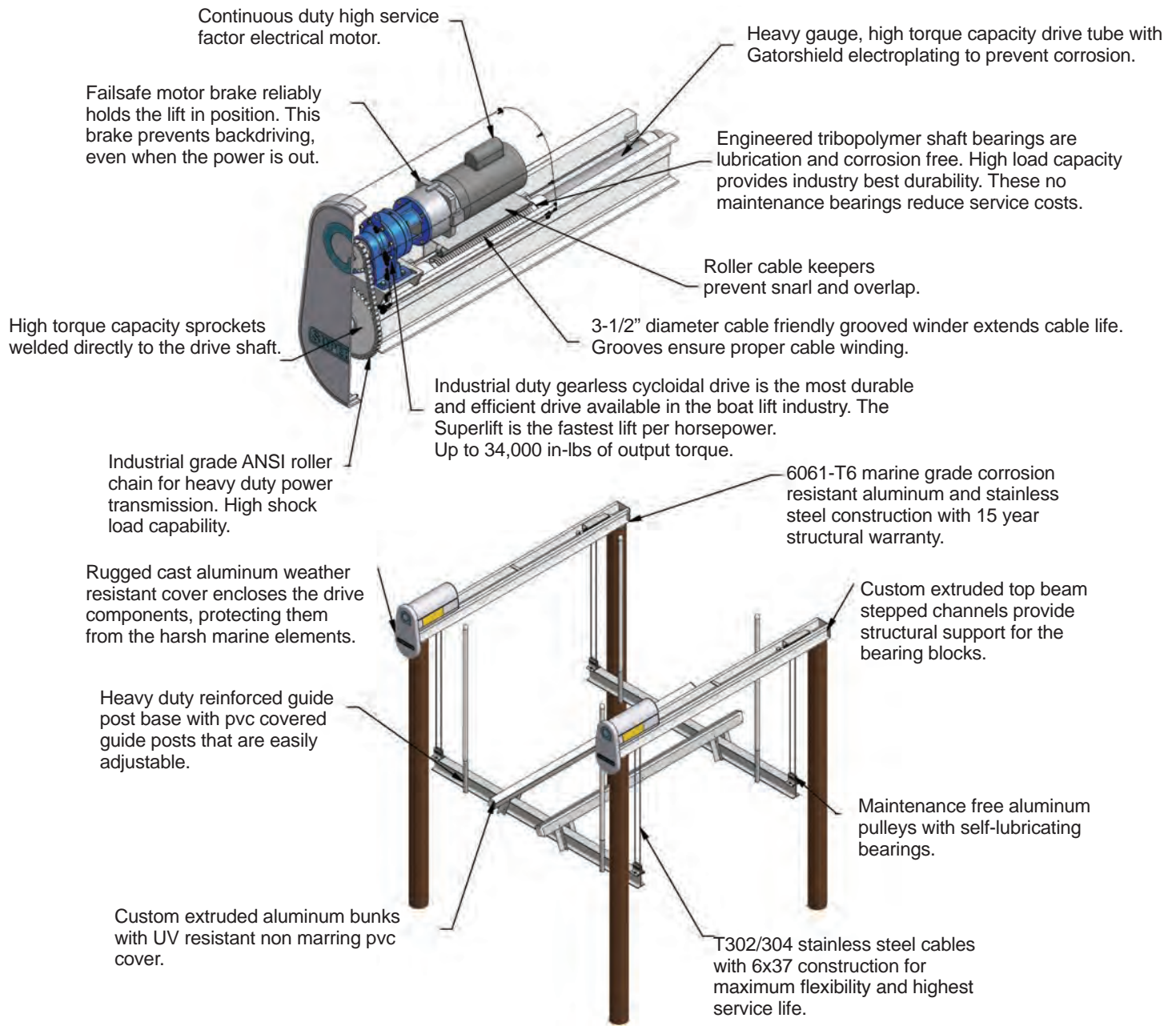

Lift Speed Comparison Chart for Four Post Lifts

Superlift Hi Speed	inches / minute	Golden Sea-Drive	inches / minute	Hi Tide X2	inches / minute	Neptune H2	inches / minute
5,000	237	5,000	39.7	4,000	80	4,000	80
7,000	182	7,000	39.7	6,000	80	6,000	80
10,000	115	10,000	19.85	9,000	40	9,000	40
14,000	89	14,000	19.85	12,000	40	12,000	40
18,000	91	16,000	19.85	16,000	40	16,000	40
22,000	77	20,000	13.2	20,000	27	20,000	27
27,000	60	24,000	13.2	24,000	27	24,000	27
33,000	51						



Titan Yacht Lifts



The ultimate boat lift on the market, our Titan line of luxury yacht lifts set a new standard of performance, safety, and reliability to lift even the largest of yachts. The Titan lifts use cycloidal drives, which are the most powerful and efficient drives in the industry, thereby maximizing output torque and lift speeds. This “Best of the Best” lift design comes standard with all the bells and whistles, including:

- Completely enclosed aluminum upper beams with tinted inspection windows that is powder coated to match any color.
- Custom bunk and cradle systems are engineered in consultation with the yacht manufacturer to provide the perfect fit and proper hull support.
- One-piece, solid aluminum drive shaft/grooved cable winders with extra-pleiable 6 x 37 construction stainless steel cables and dual auto-tension cable rollers.
- Maintenance free, self-aligning pillow block sealed shaft roller bearings and large radius, maintenance-free aluminum pulleys with articulating brackets.
- Variable frequency drive with PLC controls that increase speed, enable soft start and stop, are self-leveling and allow multiple stop-points. Can be used with a handheld transmitter or with your smartphone.



Titan 120,000 lbs. lift with a Nor-Tech 80' Roadster



Previous generation Titan



Titan bunks



Titan 120,000 lbs. lift in a nautical boat garage

Standard Features:

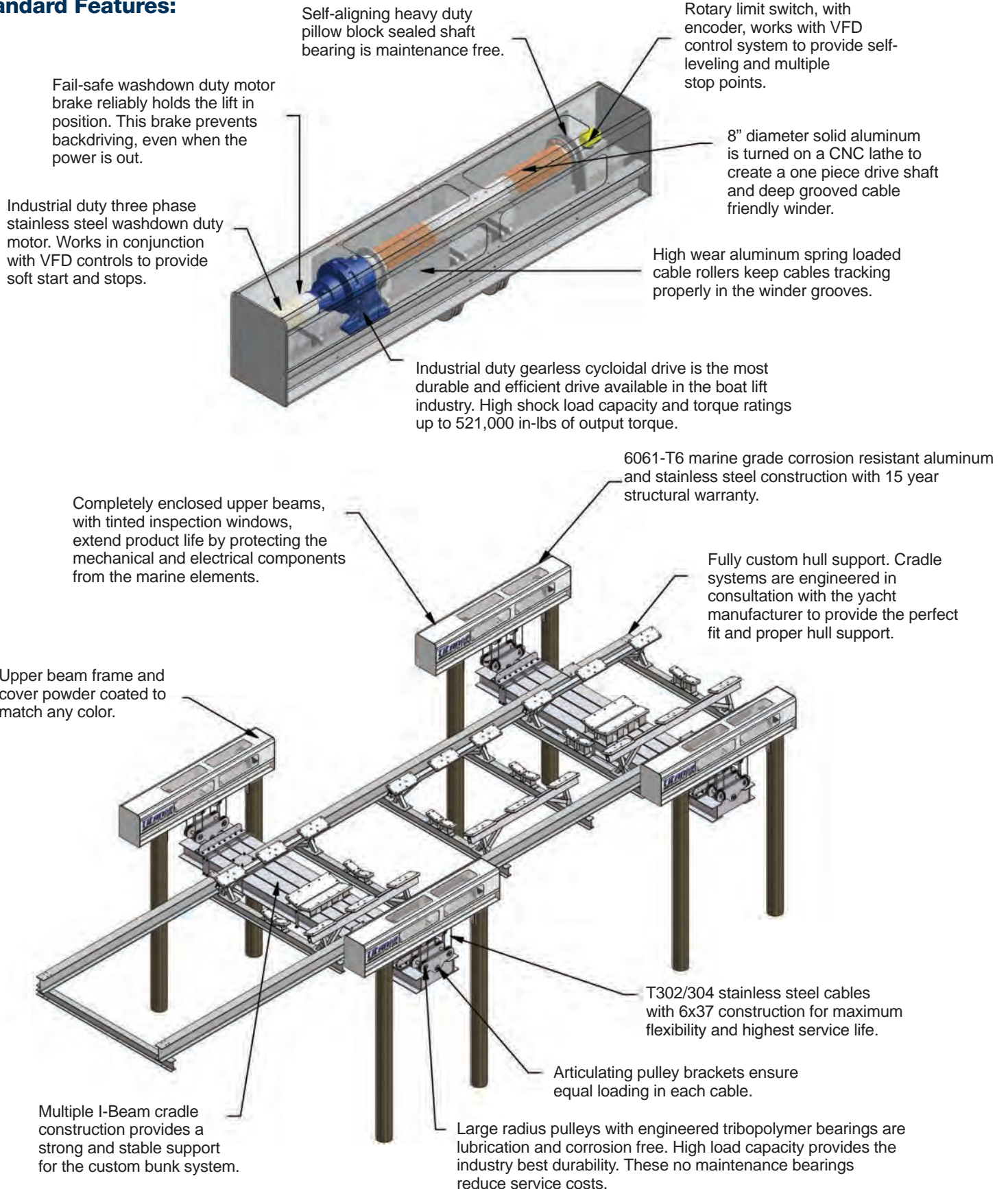

Elevator Lifts



Elevator lifts are used on restricted waterfronts where outboard pilings are not allowed, such as on narrow canals, or where the driving of pilings is difficult due to hard bottom conditions. IMM Quality's elevator lifts can be mounted on seawalls or pilings and in a vertical or inclined position. Our elevator lifts are gusseted using one inch thick billet aluminum plates which have CNC machined channels that accept the upper and lower flanges of the carriage arm I-beams. No other manufacturer has this feature. Not only does this provide mechanical support in this critical joint, but it also guarantees the correct geometry in all 3 dimensions for the arms. With IMM Quality's superior

manufacturing capabilities, there is no need to worry about over-stressed welds, bolts or your elevator arms being out of alignment. The Elevator lifts are available in two styles:
1. The Alumavator, featuring our chain drive, a premium lift at an economical price. The Alumavator comes standard with carpeted wooden bunks, Bonita manual control and GFCI.
2. The Platinum, featuring a double worm direct drive, is engineered for a truly maintenance-free experience. The Platinum comes standard with white vinyl covered aluminum bunks that are guaranteed not to float and a remote control box with handheld transmitter.

Elevator lifts are available in standard capacities of 4,500, 8,000, 10,000, 13,500, 16,000 and 20,000 pounds. Elevator lifts are typically made in three installation angles: the standard 23 degree incline, 10 degree incline and vertical mount. Elevator lifts with capacities greater than 20,000 pounds and custom installation angles are available upon request.

Alumavator Options:

- Available in a High Speed version that is twice as fast
- Remote control with handheld transmitter
- Aluminum bunks

General Options:

- Can also be made with our Superlift drive system
- Auto-stop limit switches
- Walkboards, steps and hinged boarding platforms
- ThruFlow decking
- Solar power



Standard Features:

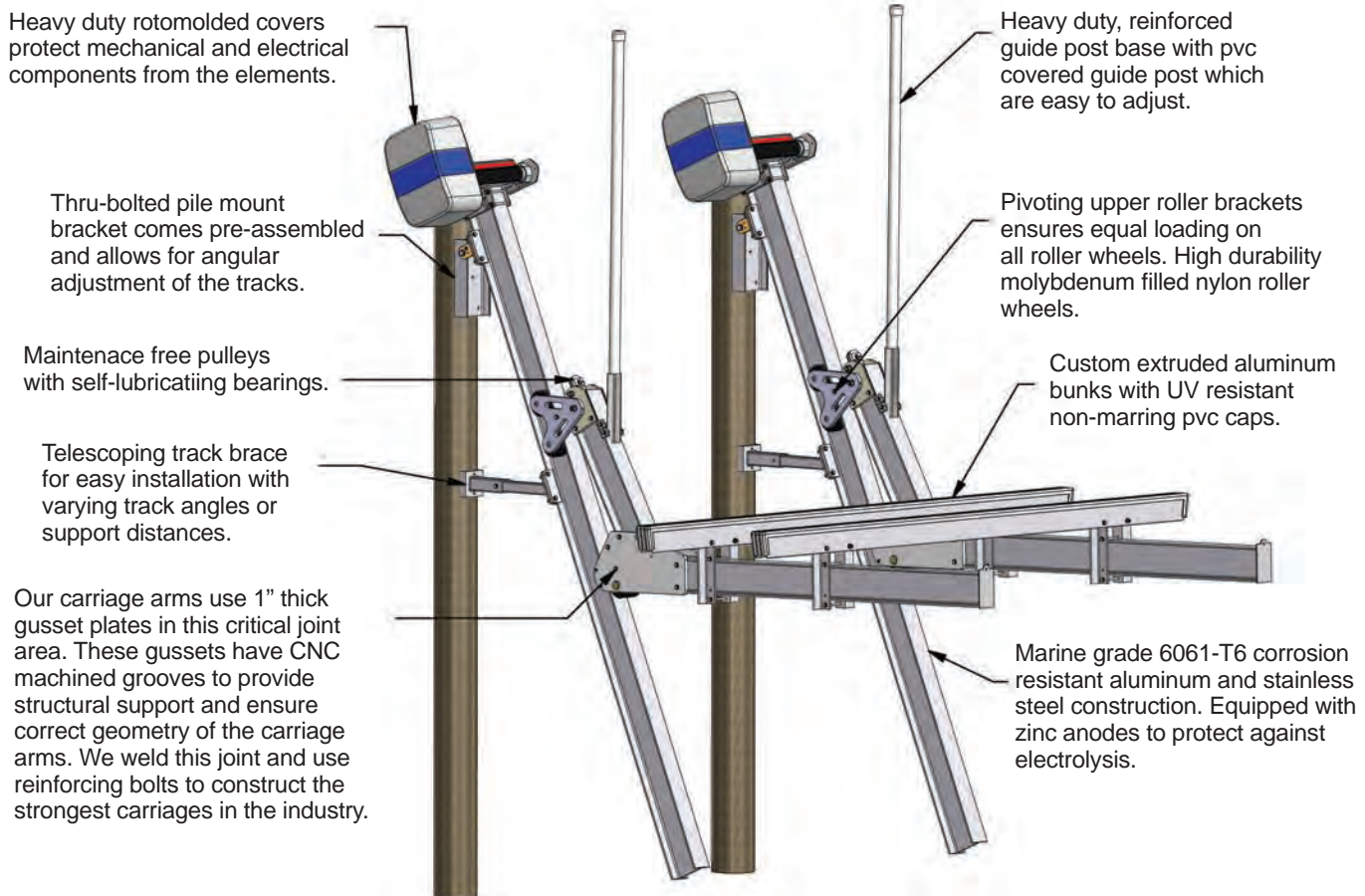
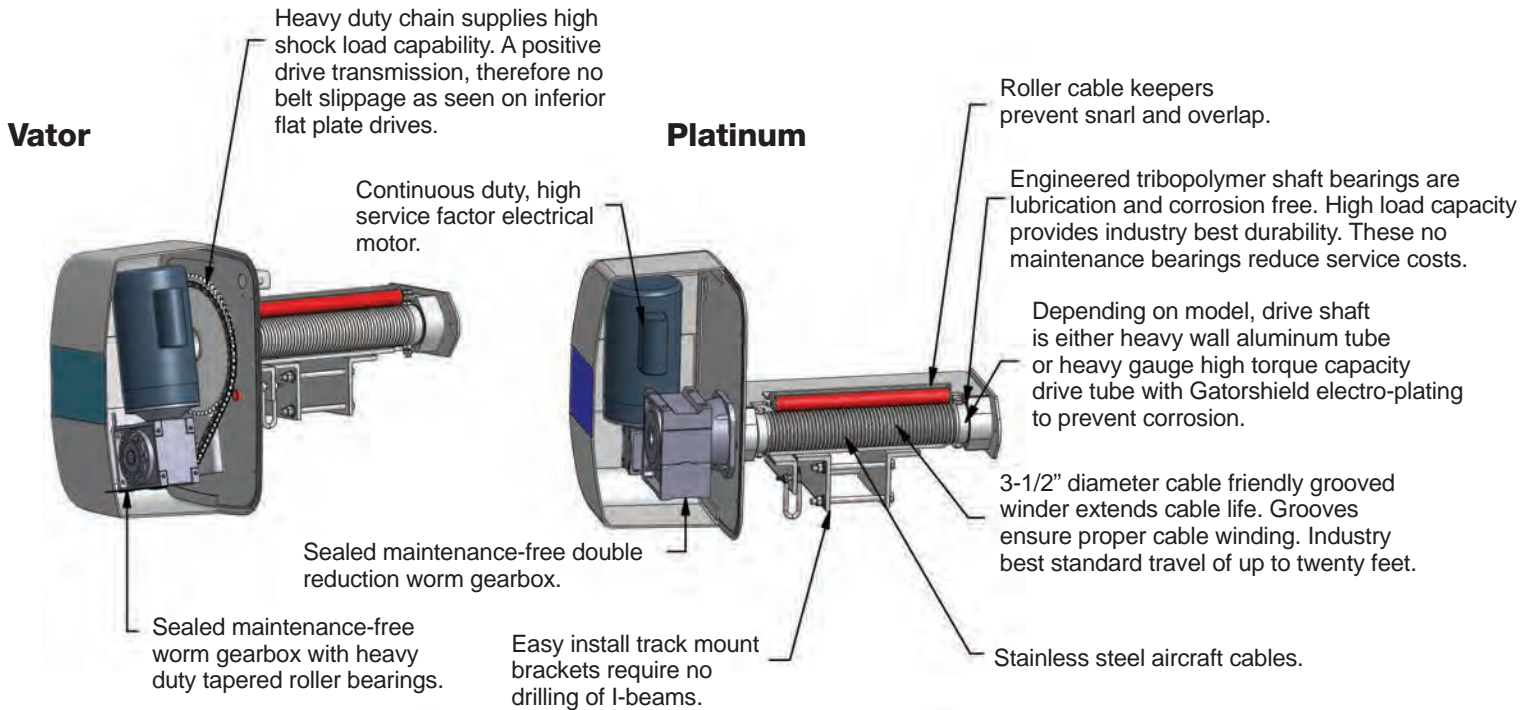

PWC Lifts

PWC 1,500 & PWC 3,000



PWC 1,500

The **PWC 1,500 Swivel** is a single pile mounted lift powered by our chain drive that was specifically engineered for personal water craft such as jet skis and kayaks. Our mounting bracket allows the carriage arm to rotate 180° to make changing the position of your PWC from over water to over dock easy. When raised, all components of the lift remain out of the

water, so there is no need for sacrificial zinc anodes. For kayak applications, we manufacture a custom ThruFlow access platform which will raise and lower with the lift. Take a look below to see why our PWC 1,500 is the most user-friendly and versatile PWC lift on the market.

Nylon roller tube guides allow for smooth operation of the carriage.

Stainless steel aircraft cables.

Grooved nylon cable winder allows for even cable winding with quiet operation and greater durability for both winder and cable.

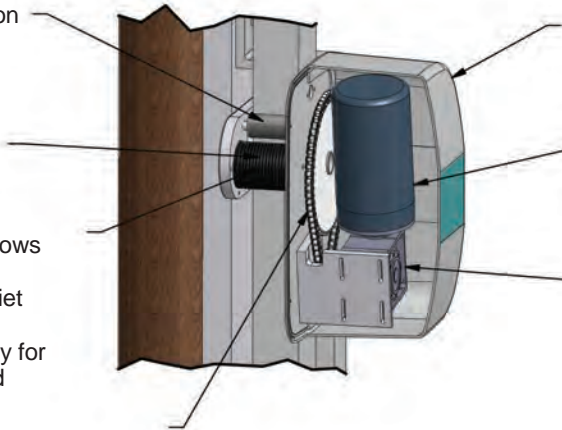

Heavy duty rotomolded cover protects mechanical and electrical components from the elements.

Continuous duty high service factor electrical motor.

Sealed maintenance free worm gearbox with tapered roller bearings.

Marine grade 6061-T6 corrosion resistant aluminum and stainless steel construction.

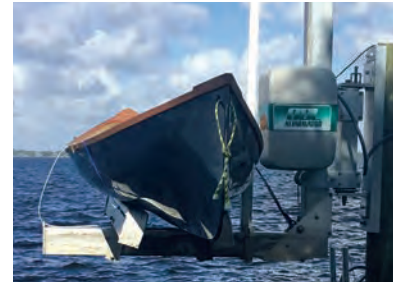

Heavy duty chain supplies high shock load capability. A positive drive transmission, therefore no belt slippage as seen on inferior flat plate drives.

Mounting bracket allows the carriage arm to rotate 180 degrees to make changing the position of your PWC from over water to over dock easy. Pivot bearings are self-lubricating and maintenance free.



Heavy duty reinforced guide post base with pvc covered guide post which is easy to adjust.

Custom extruded aluminum bunks with UV resistant non-marring pvc caps.

Heavy duty rectangular tube construction provides superior strength and stiffness versus I-Beam designs. Simplified design provides sturdy support for the bunks.



Lifts come pre-assembled for easy installation, just thru-bolt to the pile.

Our carriage arms use gusset plates in this critical joint area that have CNC machined grooves that accept the flanges of the I-beams. This provides structural support and ensures the correct geometry of the carriage arms. Our joint is the strongest in the industry.

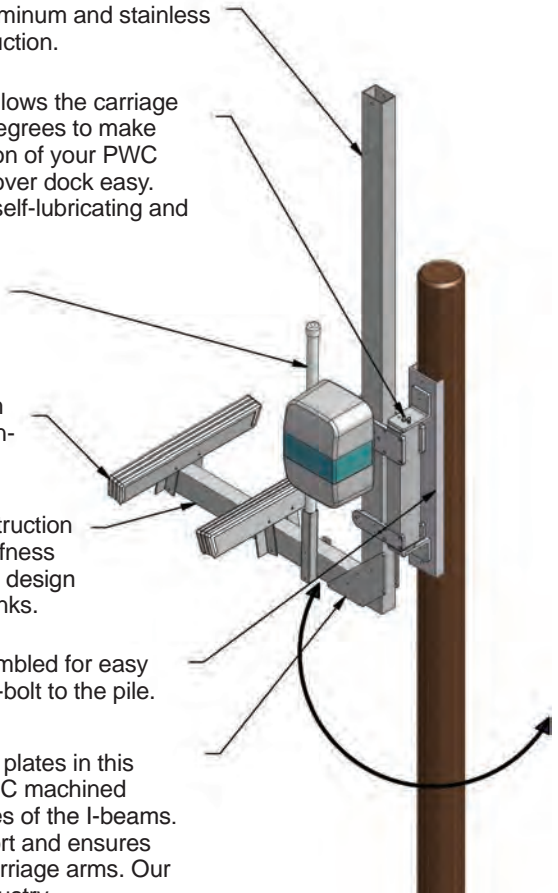

PWC 3,000

The **PWC 3,000** is ideal for everything from jet skis, sea kayaks and small skiffs. When fitted with ThruFlow decking, the PWC 3,000 is ideal for use with kayaks and other portable vessels.

Available with one or two piece tracks and either seawall, dock or piling mounts, the PWC 3,000 is sure to work for any application.

Options: ThruFlow Decking • Wireless remote controls • Auto-stop limit switches

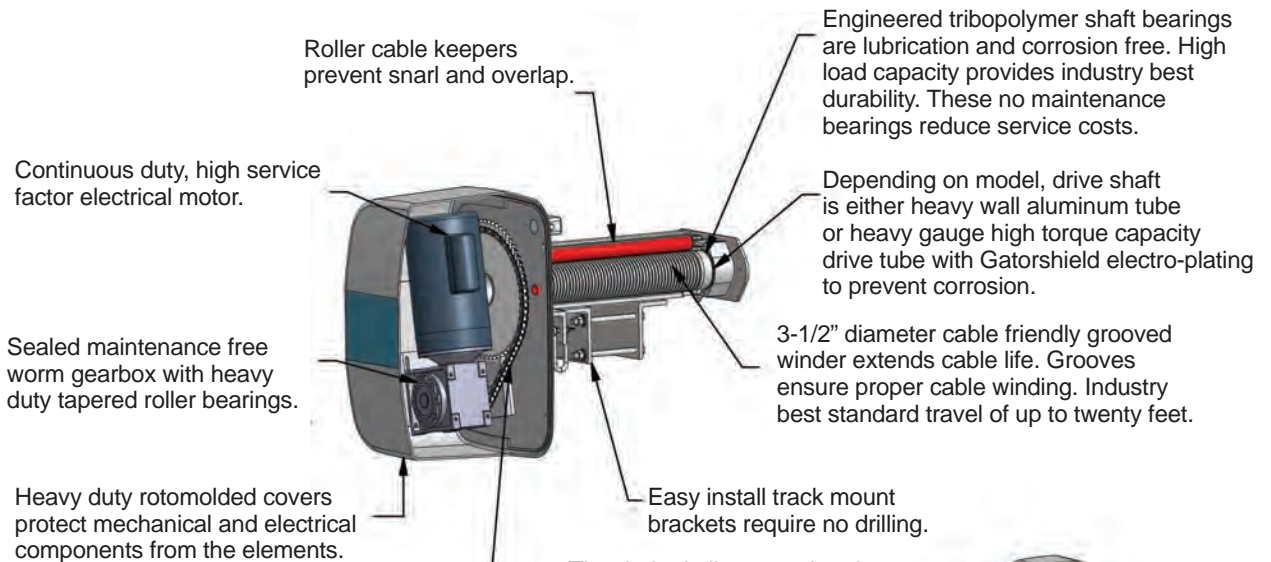

Heavy duty chain supplies high shock load capability. A positive drive transmission, therefore no belt slippage as seen on inferior flat plate drives.

Thru-bolted pile mount bracket comes pre-assembled and allows for angular adjustment of the tracks.

Maintenance free pulleys with self-lubricating bearings.

Heavy duty reinforced guide post base with pvc covered guide post which is easy to adjust.

Pivoting upper roller brackets ensures equal loading on all roller wheels. High durability aluminum roller wheels with self-lubricating bearings.

Shown with upgraded custom extruded aluminum bunks with UV resistant non-marring pvc caps. Pressure treated fully carpeted wood bunks standard.

Heavy duty rectangular tube construction provides superior strength and stiffness versus I-Beam designs. Simplified design provides sturdy support for the bunks.

Side guide nylon wheels keep the carriage in the proper position and provides smooth operation.

Marine grade 6061-T6 corrosion resistant aluminum and stainless steel construction. Equipped with zinc anodes to protect against electrolysis.

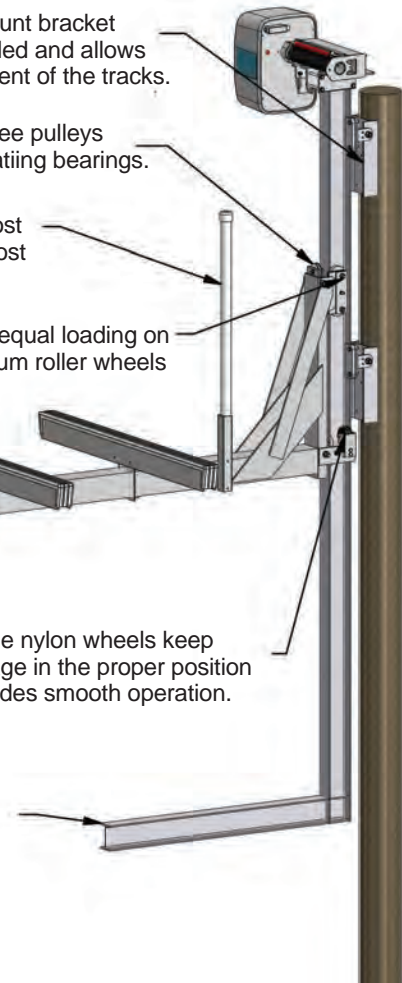

Boathouse Lifts



IMM Quality Boat Lifts has many solutions to accommodate your boathouse lift needs. Lift Hanger Bearings are the most common and effective way to mount a lift inside of a new or existing boathouse. This is the style we refer to when we talk about our boathouse lift. The drive bearings are fastened to a hanger assembly which slides over the stringer bands of the boathouse. Once in place, the brackets of the hanger assembly are fastened to the stringer bands using stainless steel bolts placed immediately above and below the stringer band, thus no drilling of the bands is required. With our Lift Hanger Bearings, your lift installation is not dictated by piling layout and maximizes slip usage (width). Our lift hanger brackets are great for retrofits into existing boathouses. The hanger brackets allow easy access to the lift components, therefore the replacement or repair of our Boathouse lift does not require alteration of boathouse structure.

Our Boathouse lifts are available in two styles: **1. The Alumavator**, featuring our chain drive, a premium lift at an economical price. The Alumavator comes standard with carpeted wooden bunks, Bonita manual control and GFCI. **2. The Platinum**, featuring a double worm direct drive, was engineered for a truly maintenance-free experience. The Platinum comes standard with white vinyl covered aluminum bunks that are guaranteed not to float and a remote control box with handheld transmitter.

Our Boathouse Lift hanger brackets allow for an out of sight installation and coupled with our no-maintenance Platinum drive, our Boathouse Lift is truly unobtrusive and worry free.

Boathouse lifts are available in standard capacities of 4,500, 7,000, 10,000, 13,000, 16,000, 20,000 and 27,000 pounds

Lift hanger brackets slide over the boathouse structural band and are fastened using stainless steel bolts. Requires no drilling of the structural bands.

Heavy duty rotomolded covers protect mechanical and electrical components from the elements.

Easily adjustable, heavy duty guide post base with PVC covered guide posts.

Fully carpeted pressure treated wood bunks.

All 6061-T6 aluminum and stainless steel construction.

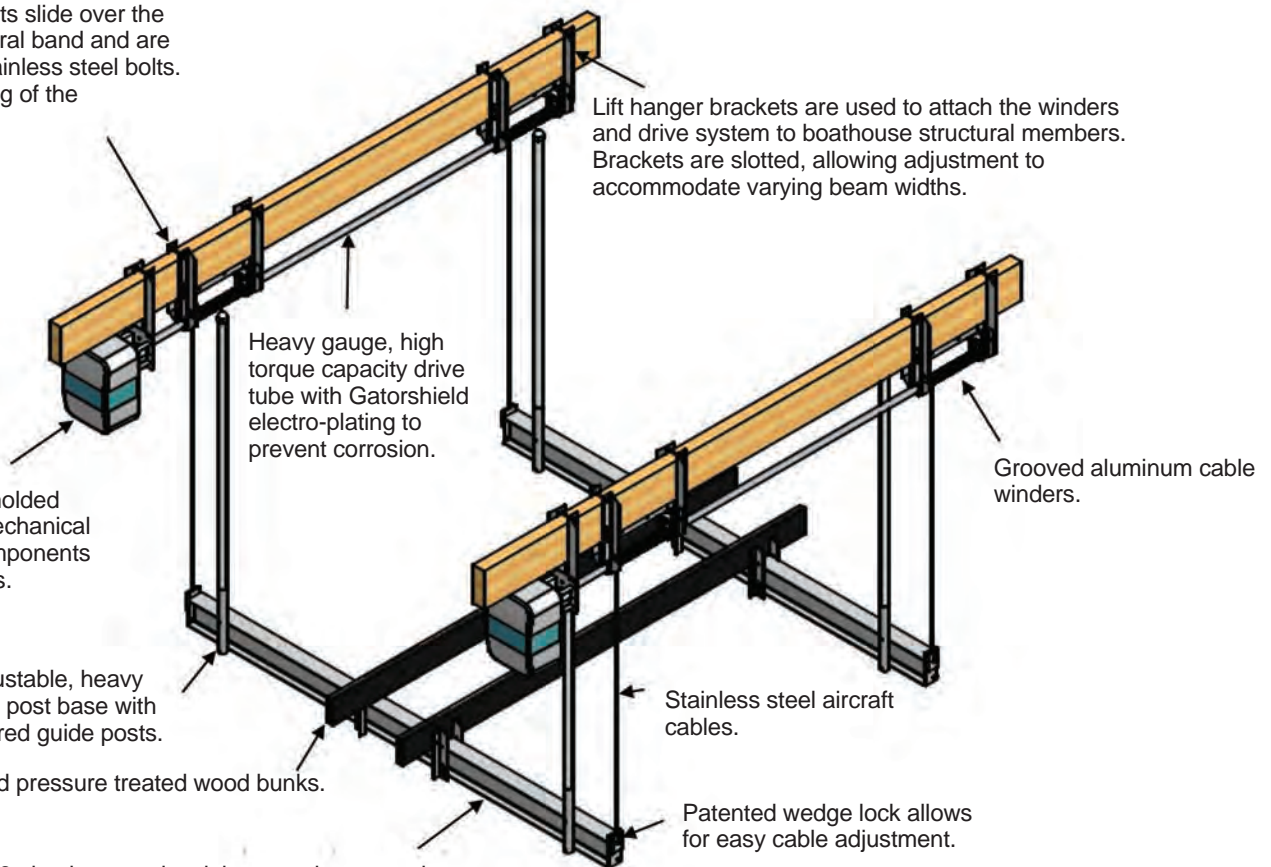

We also have three other mounting brackets that allow you to place a traditional beamed lift inside of a boathouse. Our engineers will design a solution for any boathouse application, so please call our custom design team today to discuss your boathouse lift needs.

Suspension Brackets allow you to hang a standard beamed lift in various positions along overhead support beams in the boathouse. This unique solution maximizes slip space by allowing full adjustability in all directions so that the lift can be positioned precisely where you want it.

Side Mounting Brackets are used for mounting a standard beamed lift to piling when the top of the piles are not accessible or other mounting means are not available. Careful examination of the piling is required to determine if the existing boathouse structure is sufficient to handle the side load forces generated with this mounting solution.

Stringer Brackets are another solution to put a standard beamed lift into a boathouse. This solution is best employed during the construction of a new boathouse. With this solution, Stringer Brackets are welded to the top of the beams of one of our standard vertical lifts. The Stringer Brackets are then attached to the boathouse stringer bands and are used to support the roofing system of the boathouse.



Suspension Bracket



Side Mounting Bracket



Stringer Bracket



Kayak Lifts



You most likely love to be on the water, enjoying the scenery, breathing in the fresh air, and making little discoveries as you explore in your kayak. Getting in your kayak is another story. Is your dock too high to safely launch your kayak? Does your dock even have a ladder down to the water? Have you come up with a method to launch your kayak that is very awkward and uncomfortable? Have seen kayak launches from other manufacturers that look poorly made, shake and wobble, and quite frankly, look unsafe to operate?

Are these issues keeping you from using your kayak as much as you would like? Are you ready to kayak without these aggravations?

The Kayak Launch developed by IMM Quality Boat Lifts is a simple solution to get you back in the water in no time. With

three generations of engineering experience, we designed the kayak launch to be easy to use, take up a minimum of dock space, and still be built strong enough to last a lifetime.

IMM Quality Boat Lift's innovative new Kayak Launch lets you easily get your kayak in and out of the water from your dock or seawall. This lift is offered with an ADA compliant built-in angled ladder for comfortable climbing. The kayak launch has a non-slip boarding platform to make getting in or out of your kayak safe and easy. The kayak launch also has an aluminum hand rail for secure boarding and added safety. The kayak launch is available in three sizes (standard, large and dual) to suit your needs. The adjustable nylon bunks can accommodate any kayak size as well as other small watercraft like canoes and paddleboards

Standard Features

- Simple Installation
- Welded Aluminum Construction / Stainless Steel Hardware
- Supports up to 1200 Pounds
- Up to 7' Travel Distance Available
- Non-Slip Boarding Platform
- Adjustable Nylon Bunks for Kayaks of Varying Width
- Hand Winch With Auto-Brake Controls Up-And-Down Movement
- Grab Rails Provide Stability During Boarding
- Adapts to Fluctuating Water Levels
- No Components Below Water in Up Position

Options

- Mounts to Seawalls or Permanent Docks
- Electric Winch with Solar Power
- Built-in Paddle Hooks
- Regular Platform (16" by 40", 700 lbs Capacity)
- Large Platform (24" by 48", 1,000 lbs Capacity)
- Dual Launch Platform (24" by 72", 1,200 lbs Capacity)



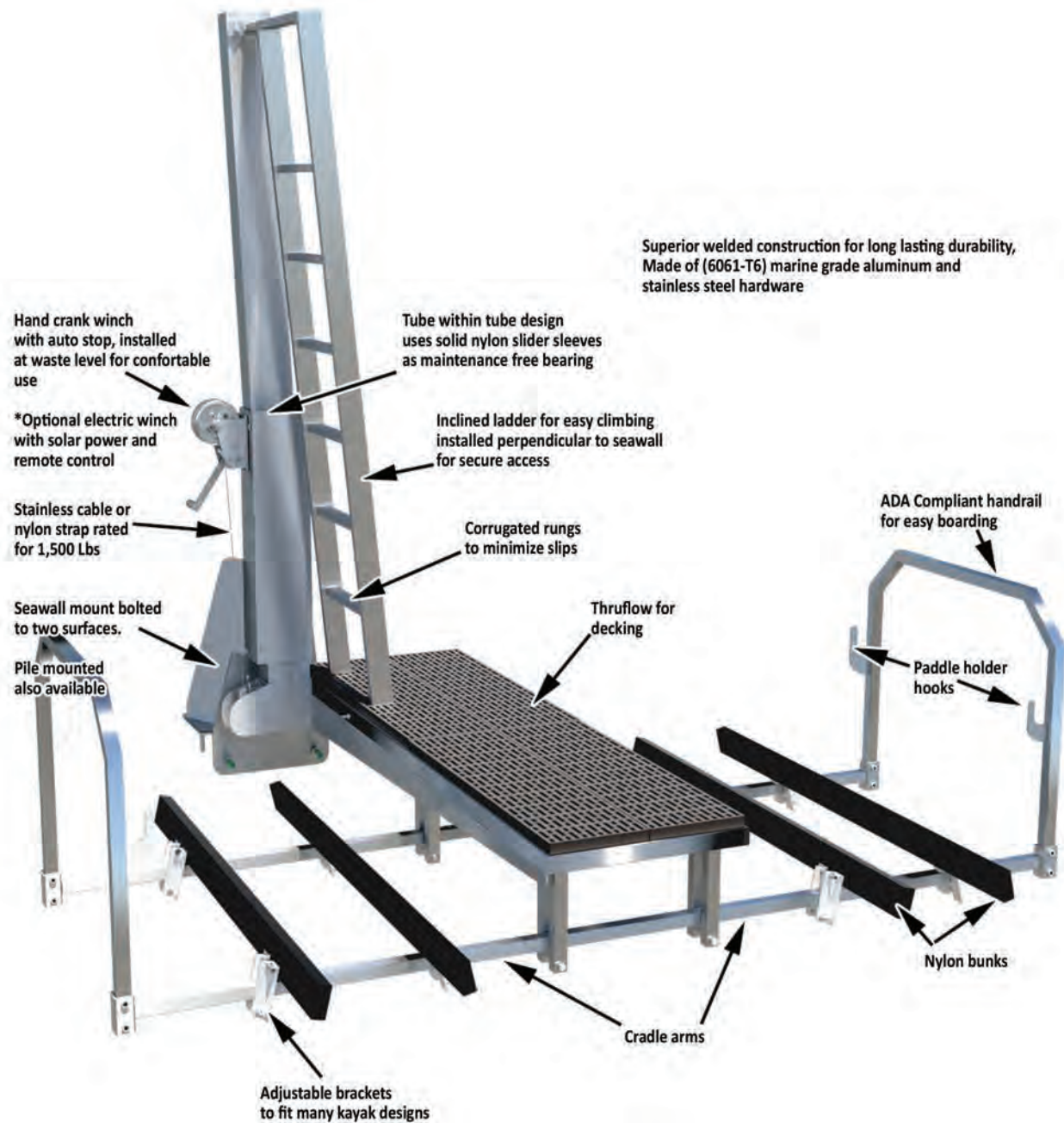



Beamless Lifts

Beamless winch lifts are preferred by many homeowners because there are no beams to avoid when boarding the boat or to obstruct the view of the waterway. The IMM Quality Beamless lift has four individual powerheads to allow independent adjustment at all corners. Our Beamless lift utilizes the Platinum drive, an aluminum double worm transmission for a maintenance-free direct drive-to-shaft connection. The Beamless lift comes standard with white vinyl covered

aluminum bunks that are guaranteed not to float and a GEM 4 remote control box with handheld transmitter and built in auto-stop limit switches. We DO NOT use load-bearing, underwater cable tie-offs on our Beamless lifts that can make the lift difficult to install, inspect and service. This also decreases the durability and safety of other manufacturer's lifts by unnecessarily keeping these load bearing parts under water where they are subject to corrosion and electrolysis.

Options: Walkboards, stern platforms, steps and hinged boarding platforms

Standard Features:

Heavy duty rotomolded covers protect mechanical and electrical components from the elements.

Continuous duty, high service factor electrical motor.

Sealed maintenance free double reduction worm gearbox.

4-1/2" diameter cable friendly grooved winder extends cable life. Grooves ensure proper cable winding. Industry best standard travel of up to twenty feet.

Engineered tribopolymer shaft bearings are lubrication and corrosion free. High load capacity provides industry best durability. These no maintenance bearings reduce service costs.

Roller cable keepers prevent snarl and overlap.

Integral pile mount thru-bolted to the pile.

Custom extruded aluminum bunks with UV resistant non marring pvc caps.

Heavy duty reinforced guide post base with pvc covered guide posts that are easily adjustable.

All 6061-T6 aluminum and stainless steel construction.

Powerheads are offset to avoid protrusion into slip area.

Stainless steel aircraft cables.

Maintenance free aluminum pulleys with self-lubricating bearings.

Beamless lifts are available in standard capacities of:

- 7,000
- 10,000
- 13,000
- 16,000
- 20,000
- 24,000 lb.



Trident Lifts



The Trident design is ideally suited at the ends of canals where waterway rights are limited to pie shaped wedges. The Trident 3 pole design satisfies triangular riparian setback limitations and allows maximum slip utilization with easy navigation in and out of the slip. The Trident lifts are powered by the Platinum drive, an aluminum double worm transmission for a maintenance-free direct drive-to-shaft connection. The Trident lift comes standard with white vinyl covered aluminum bunks that are guaranteed

not to float and a remote control box with handheld transmitter. We DO NOT use load-bearing, underwater cable tie-offs on our Trident lifts that can make the lift difficult to install, inspect and service. This also decreases the durability and safety of other manufacturer's lifts by unnecessarily keeping these load bearing parts under water where they are subject to corrosion and electrolysis.

Standard Features:

Options:

- Walkboards, stern platforms, steps and hinged boarding platforms
- Top beam covers
- Auto-stop limit switch

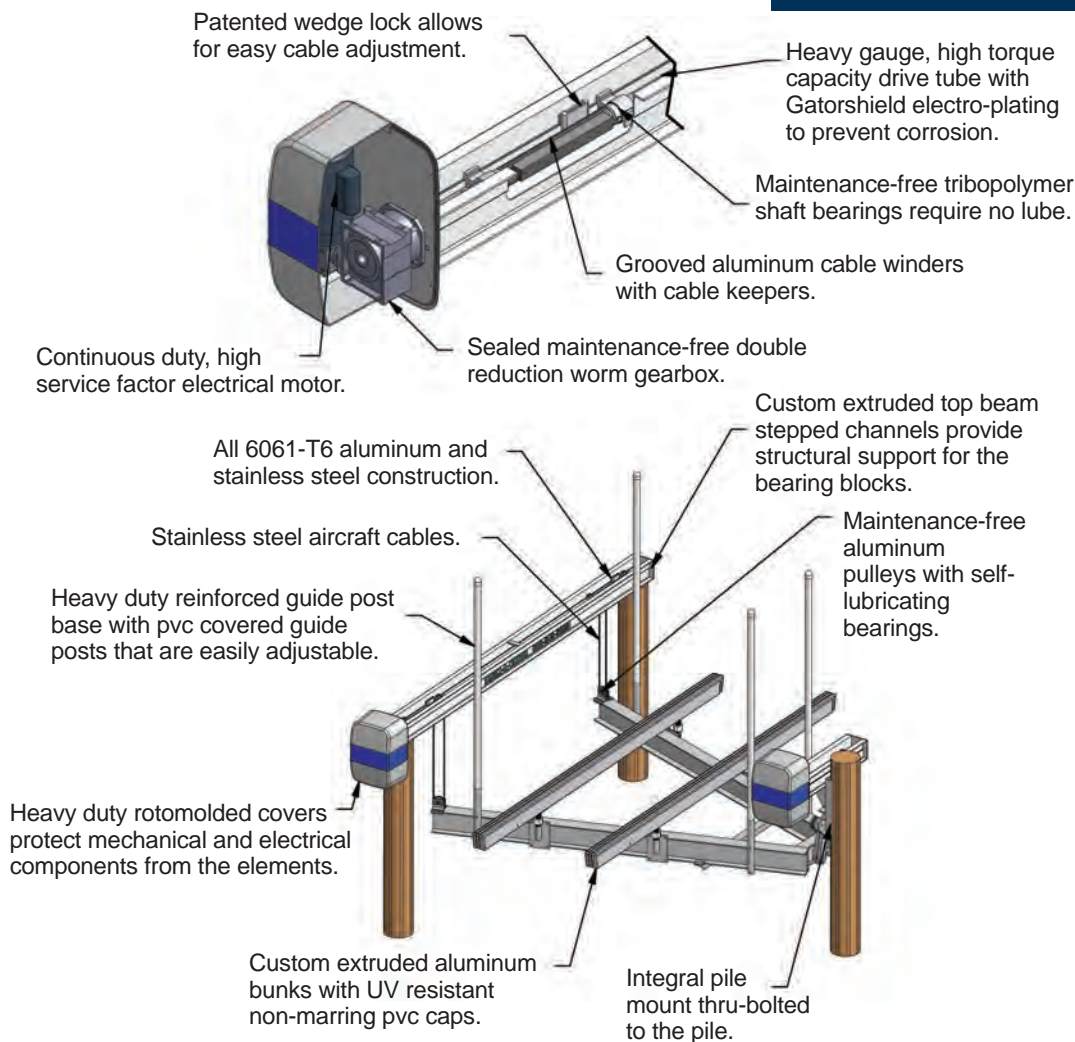

Trident lifts are available in two standard capacities of 7,000, and 10,000 pounds.

Deck Lifts



Platform lifts add versatility and convenience to your boating experience. The deck lifts can be custom built to fit all IMM Quality Boat Lift styles and capacities. Each platform has an aluminum frame that is attached to the boat lift cradle. Heat resistant, anti-slip decking panels (available in various colors) are attached to the aluminum framing. These maintenance-free panels have an environmentally friendly open grate design that allows sunlight, wind and water to flow through, keeping vegetation alive and allowing the deck lift to easily move in to and out of the water.

Custom deck lifts can be designed and built for larger vessels such as offshore center consoles and even large yachts. The

decked platforms add convenience for complete access to your vessel, making boarding and boat maintenance very easy. These platforms are also a great way to launch and service smaller vessels such as kayaks, jet skis, and flats boats. When a deck lift is paired with a remote control system, it works exceptionally well with personal watercraft. For example, a kayaker can lower their kayak into the water using the remote, and when they return, they can kayak over top of the platform, and easily lift the kayak out of the water using the remote.

Please visit the photo gallery at our website, www.iqboatlifts.com, to see all the different ways deck lifts can improve your boating experience.



Floating Docks and Gangways



We manufacture all types of floating docks, gangways and ramps using marine grade aluminum. All our aluminum docks, gangways and ramps are welded, ensuring the utmost in strength, quality and functionality while providing an attractive finish. Our floating docks are extremely stable, durable and easy to install with a variety of decking options. Each dock,

gangway and ramp is built to specification based on customer and application / site requirements. Piano style hinges can be used on either side of the gangway to allow pivoting to accommodate changing water levels. Rollers allow the gangway to roll along the top of the dock with fluctuating water levels. Options include aluminum handrails and railings.

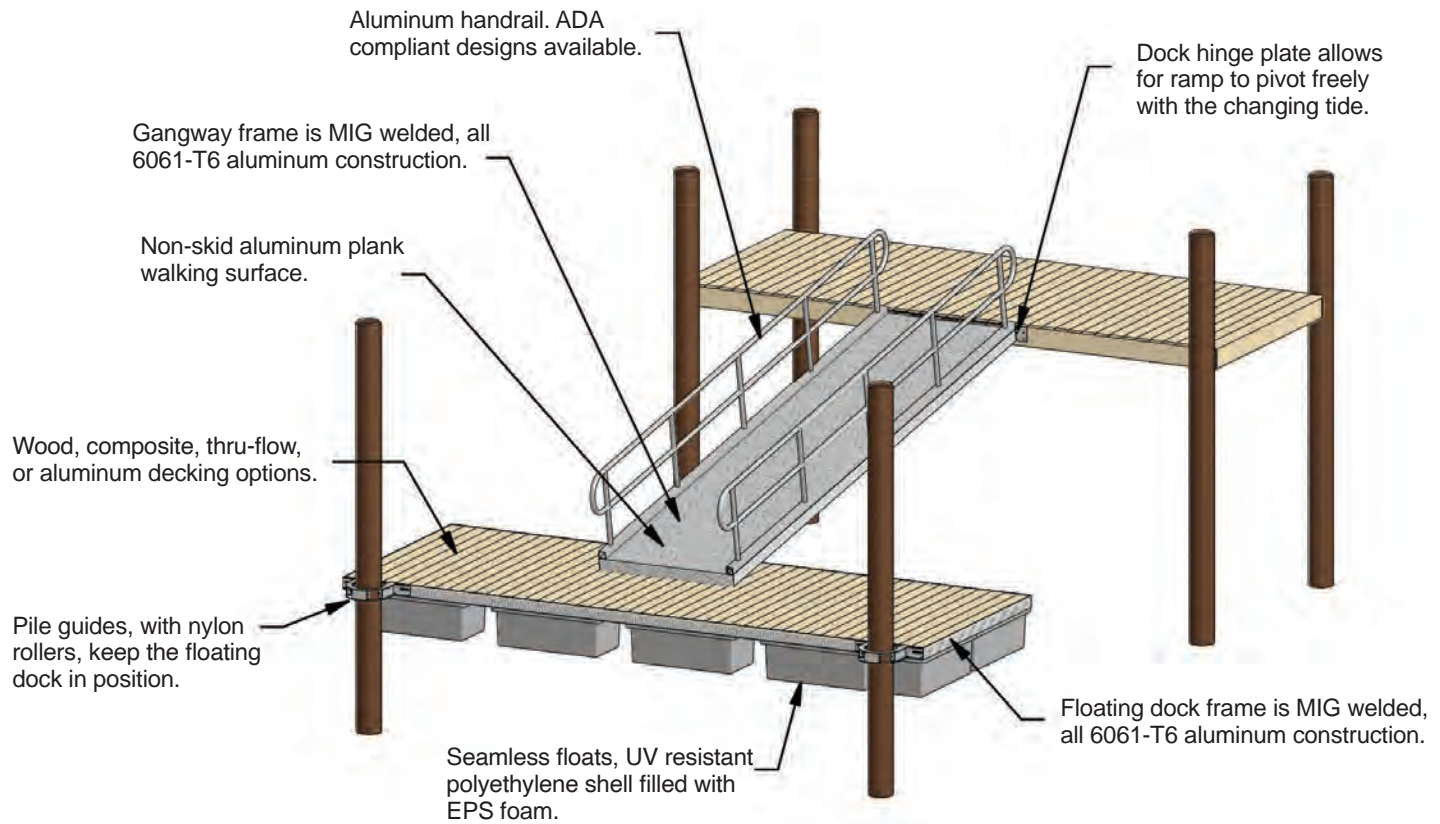

Ascension Stair Lift



IMM Quality Boat Lift's revolutionary new Ascension Stair Lift is the latest example of our innovation and engineering excellence. The Ascension Stair Lift features self-levelling steps, so you can stand on a completely flat tread no matter the height that the lift platform is raised to. The Ascension Stair Lift offers convenient water access for a variety of purposes because the stairs are capable of going both up and down. Maybe you want an adjustable height boarding platform for your

boat? Maybe you want an easy way to get your PWC, kayak, or paddle board down to the water? How about an easy access swim platform? Would you like to have stairs with a platform below the waterline so that your pets can get out of the water without help? No matter how you choose to enjoy the water, the Ascension Stair Lift provides safe and reliable water access that is easy to use.

The Ascension Stair Lift comes with the following standard features:

- Rated for 1,500 pounds
- All aluminum and stainless steel construction
- Maintenance free aluminum pulleys with unique self-lubricating bearing
- Stainless steel aircraft grade cable or nylon strap
- The articulating stairway includes an ADA compliant heavy-duty handrail
- Aluminum extruded 2' wide steps (11.5" deep) with non-slip safety treads
- Heavy-duty winch with remote control
- 7 steps provide 4' range of travel

Options

- Custom cradles and bunks to accommodate a variety of watercraft
- Custom width stairs
- Custom number of steps for greater range of travel
- Maintenance-free solar power system

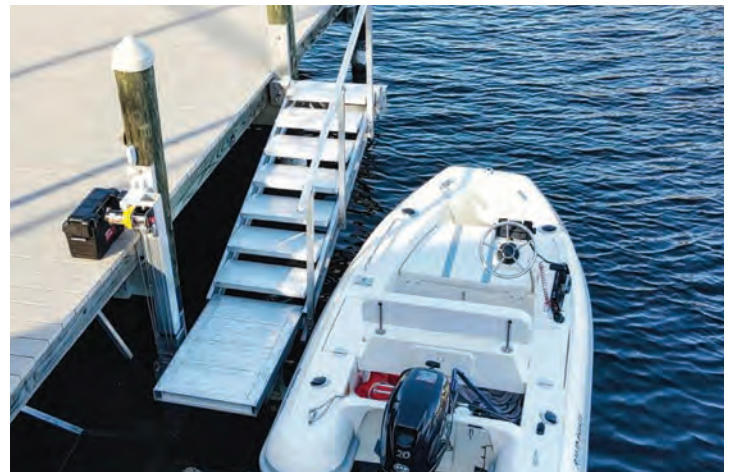

ASCENSION FOLDING STAIR & LIFT

Superior weilded construction for long lasting durability. (6061-T6) marine grade aluminum and stainless steel hardware.

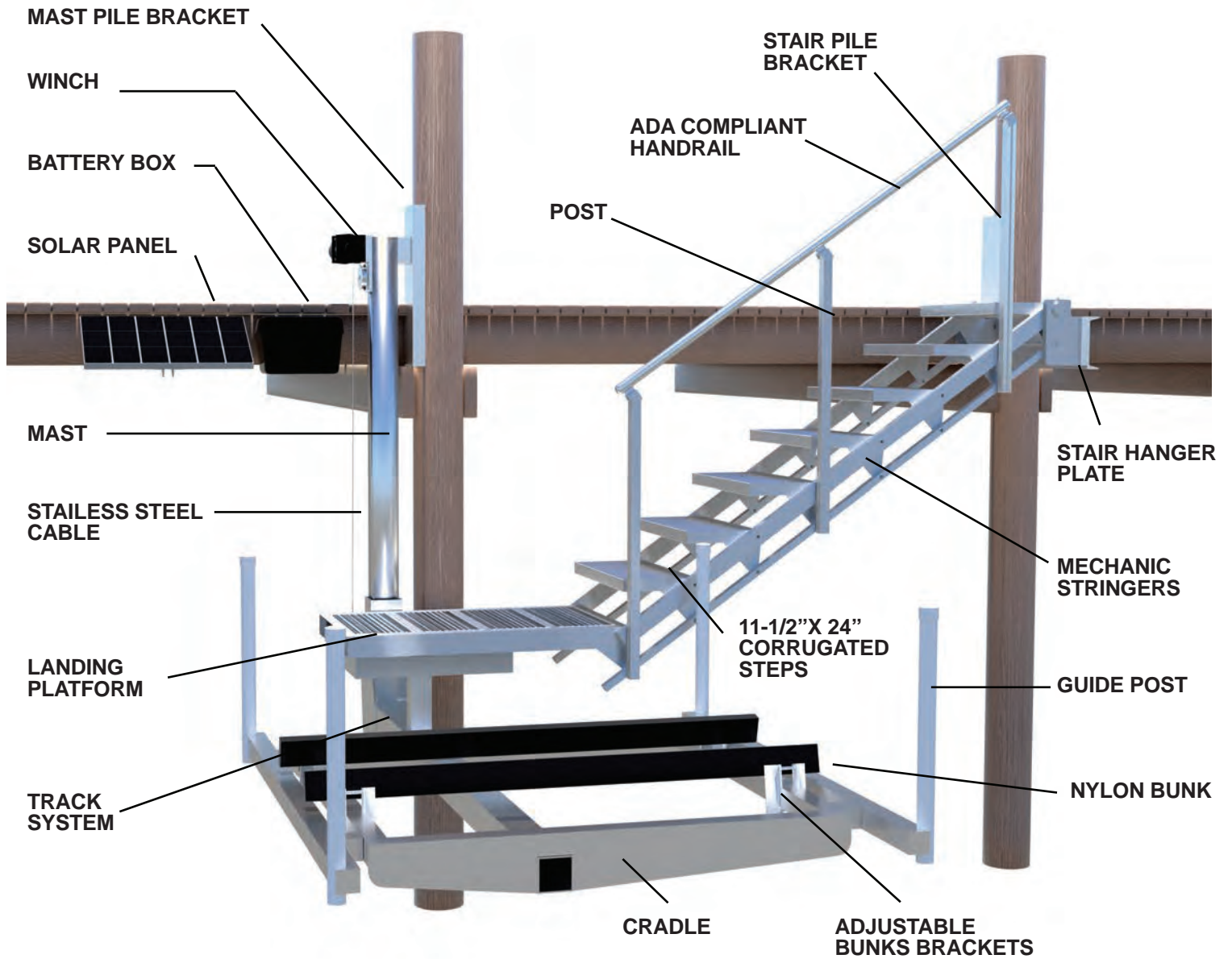

Options and Accessories

BUNK SYSTEMS AND CRADLES

THE SAILBOAT CRADLE BEAM

Assures proper positioning of a sailboat with a fixed keel.



SINGLE KICK CRADLE BEAM



ELEVATED SPREADER BRACKETS



DUAL JET SKI BUNKS



KEEL SPREADER and STANCHIONS

Used with larger boats to provide five points of contact for greater stability and to support the weight primarily on the keel beam. Our stanchions have screw jacks to allow fine adjustment of the fit of the pads to the hull.



DOUBLE KICK CRADLE BEAM



SLING BUNKS



CUSTOM BUNKS

Our engineers will design bunks to perfectly fit any type of boat.



FLAT BUNKS



PONTOON RISERS



BUNKS

STEPPED BUNKS



WOOD BUNKS



ALLUMINUM BUNKS



IMM Quality Boat Lifts

MOTORS AND GEARBOXES

AMERICAN MADE MOTORS



STAINLESS STEEL MOTORS



GEARBOXES



STEPS AND WALKWAYS

THREE STEP



CUSTOM SIZED STEPS



TOP BEAM COVERS

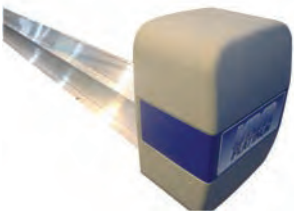

GANGWAY



HINGED PLATFORMS

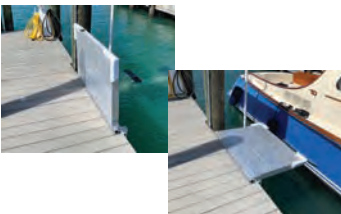

STERN PLATFORMS

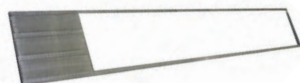

WALKWAYS



CONTROLS

BONITA MANUAL CONTROL

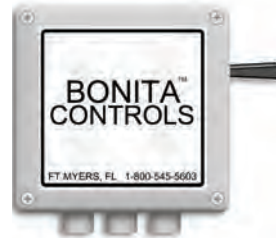

HANDHELD TRANSMITTERS



TECH II



GEM REMOTES



FOUR POLE DISCONNECT



BRACKETS AND MOUNTS

HEAVY DUTY GUIDE POST RECEIVER



PWC GUIDE POST RECEIVER



BUNK BRACKETS



GUIDE POST BRACKET



PILE MOUNT



SHARE-A-PILE



SIDEMOUNT



TIDE GUIDE



PILE HOOP



MISCELLANEOUS

SPLIT BALL WEIGHTS



30 LB. WEIGHTS



PULLEYS



NO-MAINTENANCE BEARINGS



ZINC ANODES



STAINLESS STEEL CABLE



AUTO-STOP LIMIT SWITCHES



GROOVED ALUMINUM CABLE WINDERS



CABLE KEEPER



POWERHEAD COVERS



CABLE ROLLERS



MARINE RAILWAY



POWDER COATED TOP BEAMS



LADDERS



POWDER COATED CRADLES



PILE CART



PERFORATED DECKING



SOLAR POWER UPGRADE KIT



Boatlifts 800-669-3515

Imm Boatlifts 800-669-3515

Imm Boatlifts 800-669-3515

Imm Boatlifts 800-669-3515

Imm Boatlifts 800-669-3515

Imm Boatlifts 800-669-3515

Imm Boatlifts 800-669-3515

Imm Boatlifts 800-669-3515

Imm Boatlifts 800-669-3515

Imm Boatlifts 800-669-3515

Imm Boatlifts 800-669-3515

Imm Boatlifts 800-669-3515

Imm Boatlifts 800-669-3515

Imm Boatlifts 800-669-3515

Imm Boatlifts 800-669-3515

Imm Boatlifts 800-669-3515

Imm Boatlifts 800-669-3515

Imm Boatlifts 800-669-3515

Imm Boatlifts 800-669-3515

Imm Boatlifts 800-669-3515

Imm Boatlifts 800-669-3515

Imm Boatlifts 800-669-3515

Imm Boatlifts 800-669-3515

Imm Boatlifts 800-669-3515

Imm Boatlifts 800-669-3515

Imm Boatlifts 800-669-3515

Imm Boatlifts 800-669-3515

Imm Boatlifts 800-669-3515

Imm Boatlifts 800-669-3515

Imm Boatlifts 800-669-3515

Imm Boatlifts 800-669-3515

Imm Boatlifts 800-669-3515

Imm Boatlifts 800-669-3515

Imm Boatlifts 800-669-3515

Imm Boatlifts 800-669-3515

Imm Boatlifts 800-669-3515

Imm Boatlifts 800-669-3515

Imm Boatlifts 800-669-3515

Imm Boatlifts 800-669-3515

Imm Boatlifts 800-669-3515

Imm Boatlifts 800-669-3515

Imm Boatlifts 800-669-3515

Imm Boatlifts 800-669-3515

Imm Boatlifts 800-669-3515

Imm Boatlifts 800-669-3515

Imm Boatlifts 800-669-3515

Imm Boatlifts 800-669-3515

Imm Boatlifts 800-669-3515

Imm Boatlifts 800-669-3515

Imm Boatlifts 800-669-3515

Imm Boatlifts 800-669-3515

Imm Boatlifts 800-669-3515

Imm Boatlifts 800-669-3515

Imm Boatlifts 800-669-3515

Imm Boatlifts 800-669-3515

Imm Boatlifts 800-669-3515

Imm Boatlifts 800-669-3515

Imm Boatlifts 800-669-3515

Imm Boatlifts 800-669-3515

Imm Boatlifts 800-669-3515

Imm Boatlifts 800-669-3515

Imm Boatlifts 800-669-3515

Imm Boatlifts 800-669-3515



In addition to building the finest, most reliable lifts, our full-service engineering department is unique to the industry. We have made numerous innovations and have generated the most advanced lift designs on the market. From personal watercraft to full custom designs for the largest yachts, our customers can depend on our products being exceptionally engineered and thoroughly tested.



IMM Quality Boat Lifts | 17030 Alico Center Road | Fort Myers, FL 33967 | Toll Free (800) 545-5603
Ph: (239) 432-9110 | F: (239) 432-0119

www.iqboatlifts.com