

IMM QUALITY BOAT LIFTS - ELEVATOR SPECIFICATIONS

4,500# Dual PWC

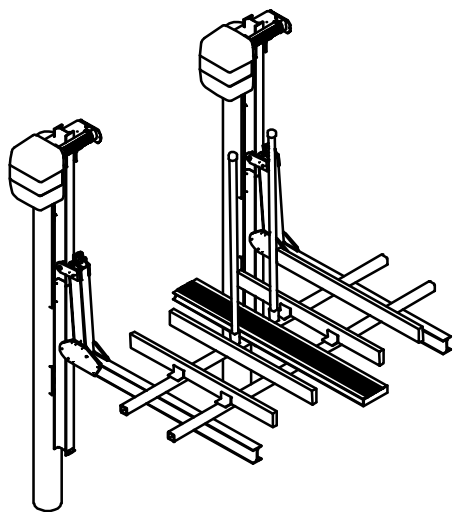

STRUCTURAL ENGINEERING REVIEW

THIS CONSTRUCTION HAS BEEN DESIGNED AS A MAIN WIND FORCE RESISTING SYSTEM, WITH CALCULATED GRAVITY AND WIND LOADS IN COMPLIANCE WITH THE FLORIDA BUILDING CODE 2014, SECTIONS 16 & 20, ADM 2010, ASCE/SEI 7-10, AND "MINIMUM DESIGN LOADS FOR BUILDINGS AND OTHER STRUCTURES" TO WITHSTAND THE WIND LOADS ASSOCIATED WITH AN ULTIMATE WIND SPEED OF 180 MPH, EXPOSURE "D", RISK CATEGORY "1". ARNOLD/SANDERS CONSULTING ENGINEERS HAS NO CONTROL OF THE MANUFACTURING, PERFORMANCE, OR INSTALLATION OF THIS PRODUCT. THESE GENERAL PLANS WERE ENGINEERED IN ACCORDANCE WITH ACCEPTED ENGINEERING PRACTICES AND DATA PROVIDED BY THE MANUFACTURER.

J.L. Sanders
10-28-16

Arnold/Sanders Consulting Engineers, Inc.
Certificate of Authorization 0461
12651 McGregor Blvd. Suite 103
Ft. Myers, FL 33919
239-267-3666

J.L. SANDERS
Reg. Florida No. 66351 Date:

SIGNATURE NOT VALID WITHOUT RAISED SEAL

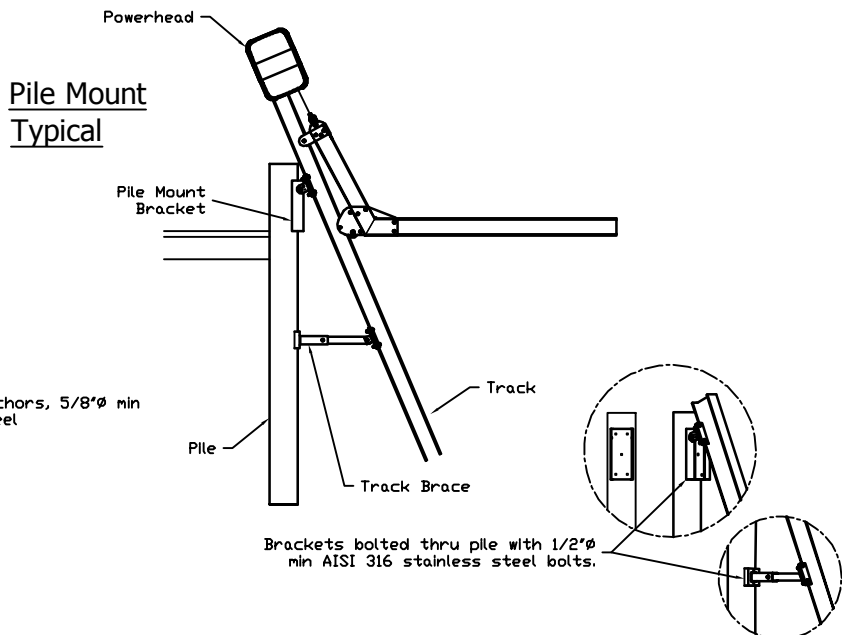
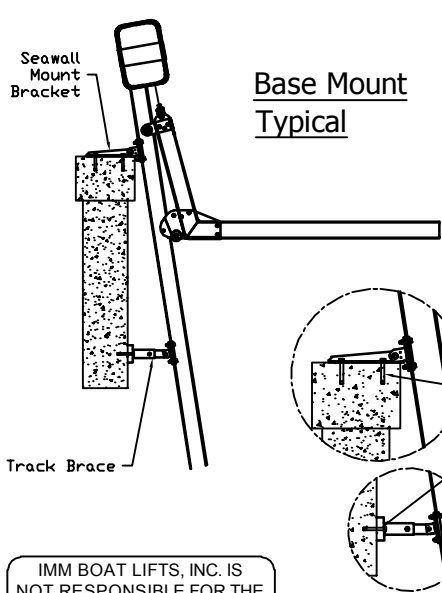

IMM BOAT LIFTS, INC. IS NOT RESPONSIBLE FOR THE DOCK STRUCTURE OR ITS ABILITY RESIST THE APPLIED LOADS OF THE BOAT LIFT. THE SITE SHOULD BE VERIFIED BY A LICENSED MARINE CONTRACTOR. APPLIED LOADS WILL BE PROVIDED UPON REQUEST.

- Notes:**
- Structure designed for loads associated with an ultimate wind speed of 170 MPH, exposure "D", risk category 1, calculated for Florida Building Code 2010, ASCE 7-10 and ADM-2005.
 - Boats shall not be stored on lifts during high wind events.
 - All primary structural members to be 6061-T6 aluminum.
 - Tracks are to be driven to firm bearing material.
 - Wood piles shall comply with ASTM D25 and be southern pine, 2.5 cca marine grade pressure treated.
 - Lateral support for piles and attachment to piles shall be engineered by others for site specific conditions.

PLATINUM

LIFT CAPACITY	CRADLE I-BEAM	TRACK I-BEAM	TRACK ANGLE OPTIONS	CABLE STD TRAVEL	CABLE EXT TRAVEL	TRACK SPREAD TYP.	GUIDE POST HEIGHT	BUNK BOARD LENGTH	DRIVE SHAFT	WINDER	DRIVE RATIO	MOTOR HP/VOLTAGE	SPEED in/min	STANDARD TRAVEL	EXTENDED TRAVEL
4,500#	6 H x .21 4 W x .35	6 H x .21 4 W x .35 x 25'	0, 10, 23	5/16 SSAC 7x19 304 2-PART 34'	5/16 SSAC 7x19 304 2-PART 49'	108"	80"	6' Alum	2.875" O.D. 8 Gauge	3" SCH 80 Pipe	375:1 Platinum	(2) 3/4 HP 115V/230V 22/11 A	26	12'	20'

ALUMAVATOR

LIFT CAPACITY	CRADLE I-BEAM	TRACK I-BEAM	TRACK ANGLE OPTIONS	CABLE STD TRAVEL	CABLE EXT TRAVEL	TRACK SPREAD	GUIDE POST HEIGHT	BUNK BOARD LENGTH	DRIVE SHAFT	WINDER DIA	SPROCKET Vator/Select	Standard Speed			High Speed			STD TRAVEL	EXT TRAVEL
												DRIVE RATIO	MOTOR HP/VOLTAGE	SPEED in/min	DRIVE RATIO	MOTOR HP/VOLTAGE	SPEED in/min		
4,500#	6 H x .21 4 W x .35	6 H x .21 4 W x .35 x 25'	0, 10, 23	5/16 SSAC 7x19 304 2-PART 34'	5/16 SSAC 7x19 304 2-PART 49'	108"	80"	6' Wood	2.875" O.D. 8 Gauge	3" SCH 80 Pipe	#50 Chain 60/11 t	327:1	(2) 3/4 HP 115V/230V 22/11 A	30	164:1 Vator	(2) 1-1/2 HP 230V 22 A	60	12'	20'

